

PolyBlend® Dry Polymer Feed System

Model DP800

The PolyBlend® DP800 system is a reliable dry polymer feed system for use in water and wastewater applications. The DP800 is an integrated equipment package capable of automatically preparing a homogeneous polymer solution.

The DP800 consists of the DD4 dry polymer disperser, a stainless steel mix tank, and a gravity fed stainless steel hold tank.

The DP800 is specifically designed to provide uniform mixing. Dry polymer and water are initially mixed in the DD4 polymer disperser exposing the solution to a high shear agitation via mechanical mixing. The high shear agitation ensures proper activation of the polymer and prevents unwanted agglomerations. After brief exposure, the solution exits the high shear mixer and flows into the mix tank.

The second stage mix is a longer, low shear mix. The rotating impeller in the secondary mix tank is a U.S. patented "hollow-wing" design and covers over half the width of the tank. The low shear mixing continuously and uniformly moves the solution vertically and horizontally resulting in no agglomerations or broken polymer chains.

When a low level is sensed in the hold tank, a valve is automatically opened and the prepared solution is gravity fed into the holding tank. From the holding tank, the homogenous polymer solution can be transferred to the process with an optional feed pump skid.

The DP800 is controlled through an easy-to-use microprocessor-based operator interface. The LCD display enables complete operation of all functions including dosage rates, solution concentration, and alarm conditions.

Key Benefits

- Reliable performance
- Field proven
- Reduced polymer consumption
- Fully automated operation
- Operator interface controls
- Improved safety features
- Easy to operate

Specifications

Electrical	208VAC/ 50-60 Hz/ 1 Ph 240VAC/ 50-60 Hz/ 1 Ph 480VAC/ 50-60 Hz/ 3 Ph 575VAC/ 50-60 Hz/ 3 Ph
Water Supply	75.7-113.6 LPM (20-30 GPM)
Tank Size	1362.8 L (360 USG)
*Polymer Feed	Up to 20.4 kg (45 lbs)/hr dry polymer based on a 0.75% solution and two (2) batches per hour
Control Panel	NEMA 4X PLC based with color touch screen
Options	See back

*Note: Consult UGSI Chemical Feed, Inc. with regards to dosing amount and your application.



General Layout

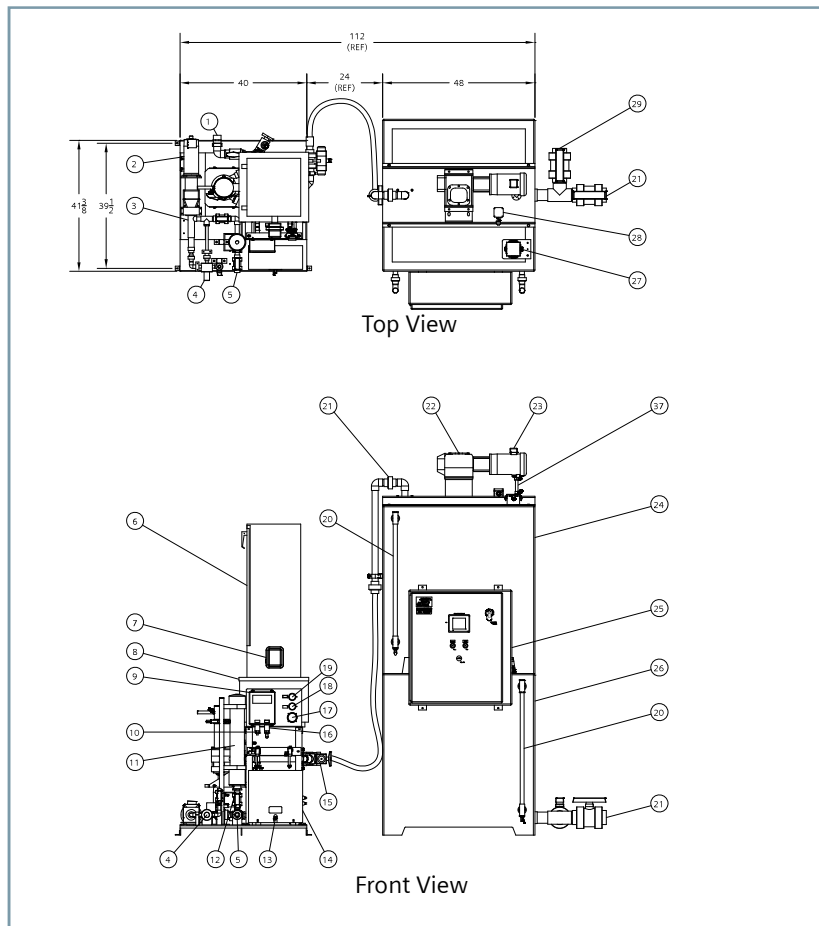

Key	Description
1	Water Inlet, 38.1 mm (1-1/2") (F)NPT
2	Motor, Progressive Cavity, 1/2 HP
3	Progressive Cavity Pump, Emulsion Polymer, 0.6 GPM (Optional)
4	Pressure Relief Valve 7.6 Bar (110 PSI) Set Point
5	Inlet, Emulsion Polymer, 12.7 mm (1/2") (F)NPT
6	Hopper with Bag Loader, 4.0 cu. ft.
7	Hopper Low Level Switch
8	Volumetric Feeder, Dry Polymer
9	Junction Box, Interconnections, NEMA 4X
10	Static Pressure Switch, Water
11	Calibration Cylinder, 4000mL
12	Isolation Ball Valve, Calibration Cylinder
13	Condensation Drain, Compressor, 6.35 mm (1/4") (F)NPT
14	Air Compressor with Tank and Cover (Optional)
15	Discharge Valve, 38.1 mm (1-1/2")
16	Static Pressure Switch, Compressed Air
17	Differential Pressure Gauge / Switch, Water
18	Pressure Gauge, Static Water
19	Pressure Gauge, Static Compressed Air
20	Sight Gauge
21	Solution Inlet, Tank, 38.1 mm (1-1/2")
22	Speed Reducer, Worm Gear, 30:1
23	Motor, Tank Mixer, 2 HP, 1725 RPM
24	Mix Tank, 1363 L (360 Working Gallons)
25	System Control Panel, NEMA 4X
26	Hold Tank, 1363 L (360 Working Gallons)
27	Mix Tank Probes, High, Low, Reference
28	Mix Tank Overflow Switch Assembly
29	Drain, Tank, 76.2 mm(3") (F)NPT
30	Pneumatic Cylinder, Isolation Plunger Actuator
31	Wetting Bowl
32	Wetting Impeller Housing
33	Automatic Flow Control Valve, Water Inlet, 114 L (30 GPM)
34	Pneumatic Ball Valve, Water Inlet, 35.4 mm (1")
35	Motor, Dispenser, 1 HP, 3450 RPM, TENV
36	Isolation Ball Valve, Emulsion Polymer Discharge, 12.7 mm (1/2")
37	Pneumatic Cylinder, Isolation Dump Valve
38	Shaft and Impeller, Mix Tank
39	Low Level Indicator, Hold Tank*
40	Overflow Switch Assembly, Hold Tank*
*	Not Shown

Available Options

- Diaphragm metering pump
- Progressive cavity metering pump
- SS gear metering pump
- Batch tanks / single or tandem
- Integral compressor
- 0.07 m³ (2.5 ft³) hopper
- 0.57 m³ (20 ft³) hopper
- Bulk bag frame
- Bulk bag frame with hoist
- Bag dump hopper
- Low powder level indication
- Over-sized feeder screw auger
- Supply water pressure reducing valve
- Final feed pumps
- Final feed post dilution
- Large hold tanks
- Transfer pumps

UGSI Chemical Feed, Inc.

1901 West Garden Road
 Vineland, NJ 08360
 Toll Free: 855-669-3845
 Local: 856-896-2160
 Fax: 856-457-5920
 Email: info@ugsichemicalfeed.com
 Website: www.ugsichemicalfeed.com

© 2014 UGSI Chemical Feed, Inc.
 Subject to change without prior notice.
 Literature No. CF.350.480.D80.PS.0714

Polyblend® is a trademark of UGSI Chemical Feed, Inc.

The information provided in this literature contains merely general descriptions or characteristics of performance which in actual case of use do not always apply as described or which may change as a result of further development of the products. An obligation to provide the respective characteristics shall only exist if expressly agreed in the terms of a written contract.