

WATER PROCESS SOLUTIONS

Chemtube 2000 Tubular Diaphragm Metering Pump

Literature Number WPSSL0500

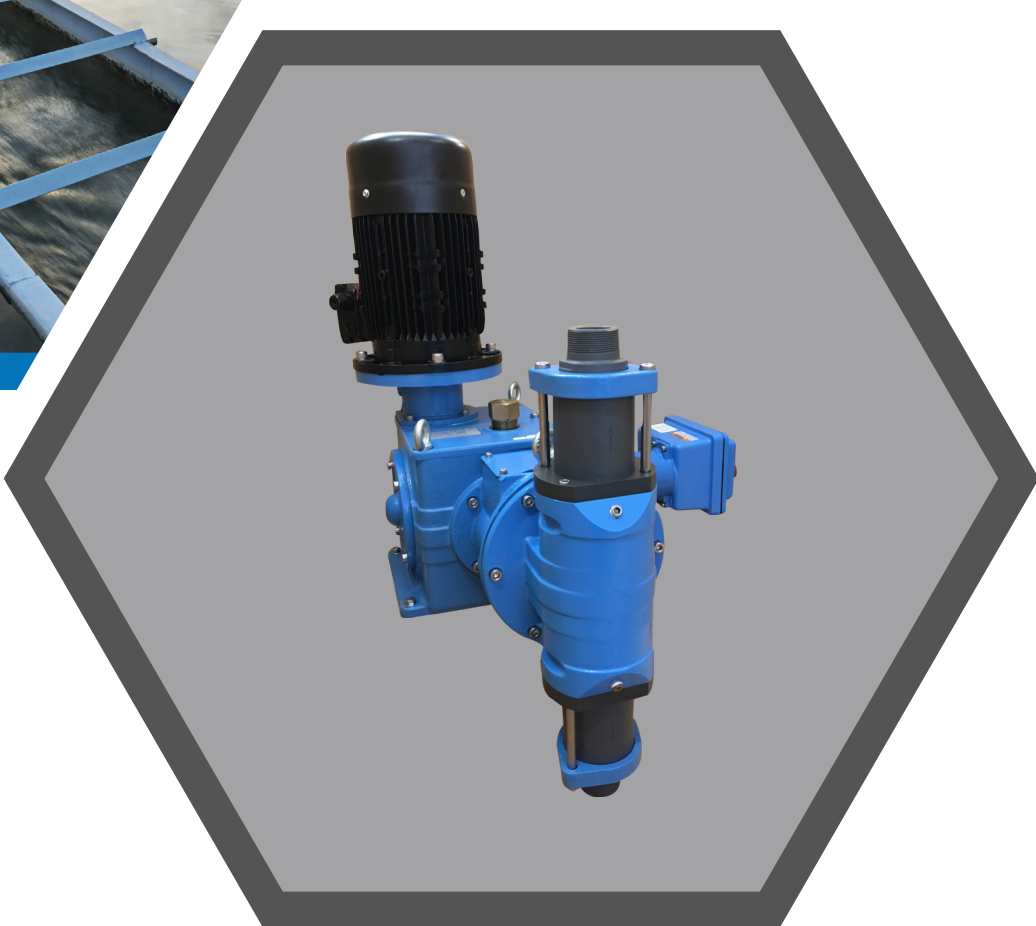

Overview

The Chemtube® 2000 tubular diaphragm metering pump is hydraulically actuated and features a rugged, compact cast iron gearbox with a hydraulically balanced tubular diaphragm for accurate chemical feed and long service life. An integral automatic refill system eliminates the need for adjustment under changing operating conditions. An optional PTFE lined diaphragm provides for chemical compatibility with virtually any chemical used in the water treatment process. Three tubular diaphragm sizes are available for capacities up to 2000 l/h (525gal/h) at pressures up to 13.3 bar.

Operation

The Chemtube® 2000 Series Pump provides accurate metering and transfer of a wide variety of chemicals and is available in three piston sizes (51, 64, and 76mm) five speeds (30, 60, 80, 120 and 144 strokes per minute), and a simplex or double simplex arrangement.

The liquid end uses two diaphragms. A flat disc diaphragm and a tubular diaphragm form a sealed intermediate chamber between the process fluid (inside the tubular diaphragm) and the hydraulic fluid (inside the piston displacement cylinder). The liquid surrounding the tubular diaphragm is a water/propylene glycol mixture (50/50) and is compatible with most process fluids. There are no mechanical connections between the two diaphragms and the pump drive. Both diaphragms are hydraulically balanced during pump operation. The disc diaphragm is driven by hydraulic fluid, which is driven by the pump piston. The piston causes the liquid in the intermediate chamber to displace the tubular diaphragm and create pumping action with each stroke of the piston.

The pump features both an in built adjustable absolute pressure relief valve and an automatic hydraulic fluid refill valve. The refill valve is mechanically actuated by sensing the position of the flat intermediate fluid diaphragm. The optional electronic leak detection system that monitors the conductivity of the intermediate fluid will automatically send a change signal given the leakage through the tubular diaphragm of the process fluid. Also, when using the optional Teflon lined diaphragm, the Chemtube 2000 pump can handle many aggressive chemicals. Finally, The stroke adjuster, either manual or electric, is capable of varying the stroke from 0 to 100% via fine increments.

Features

- Single or double ball valves for a maximum of 15 meters water suction lift.
- Non-adjustable hydraulic refill system that also protects the diaphragm from damage due to adverse suction conditions.
- Adjustable built in pressure relief valve.
- Manual or automatic stroke length control.
- Non loss motion stroke adjustment mechanism.
- Liquid end materials of construction, Valves-PVC, Kynar or stainless steel. Tubular diaphragms-Hypalon, Viton or Teflon lined.
- Double simplex arrangement also available.
- AP1675 Compliance.

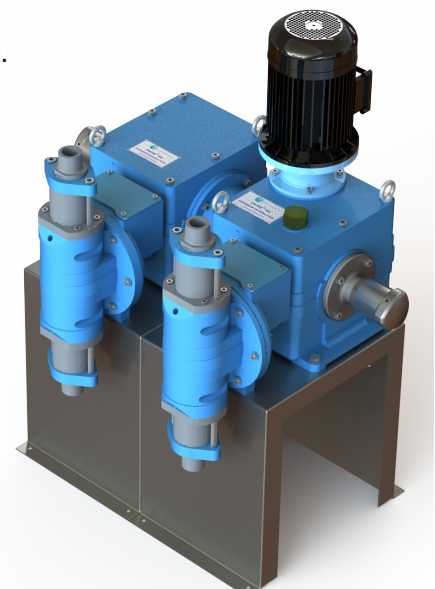

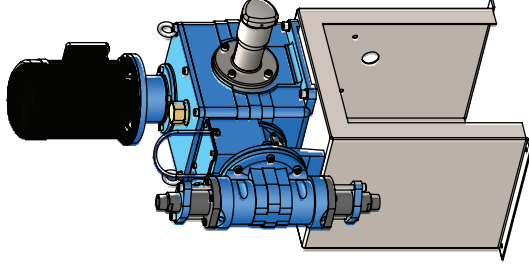
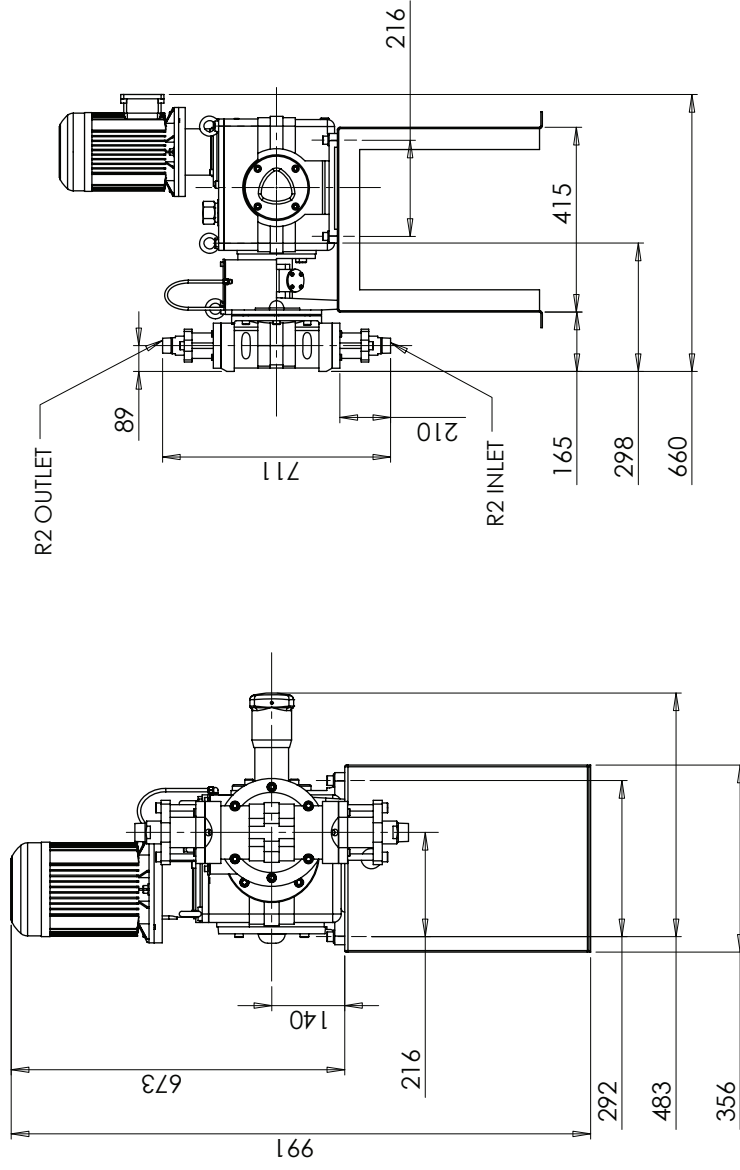
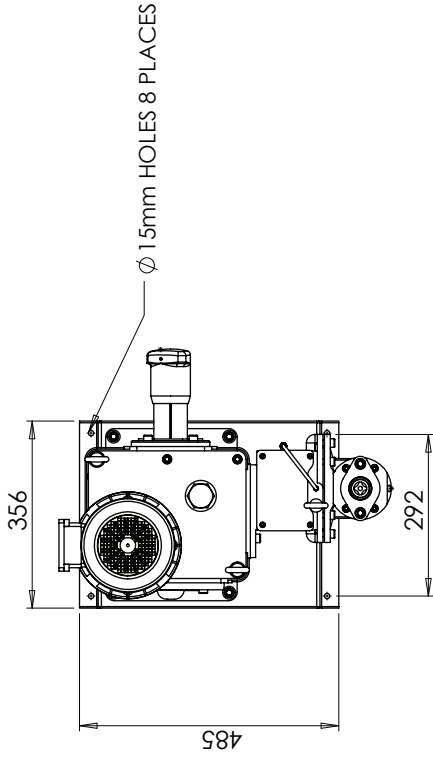

NOTE: ALL SIZES ARE IN MM. SOME SIZES MAY VARY
 DEPENDING ON MOTOR / STROKE POSITIONER VARIANT.
 THESE SIZES ARE TYPICAL OF 2000 LPH CHEMTUBE PUMPS.

PART NO.	TITLE: C-CHEMTUBE 2000 [2000 LPH] TUBULAR DIAPHRAGM PUMP - SIMPLEX MANUAL SPACE REQUIREMENTS		ISS NO. 01	DWG NO.
	PROJECT NO.			
UNLESS OTHERWISE SPECIFIED: DIMENSIONS: ALL IN MM. SURFACE FINISH: TOLERANCES: ± 0.1 mm	MATERIAL:	SCALE: 1 / 12	WEIGHT:	A3



NAME	DATE
J.W	08/09/2016
T.F	08/09/2016
T.F	08/09/2016



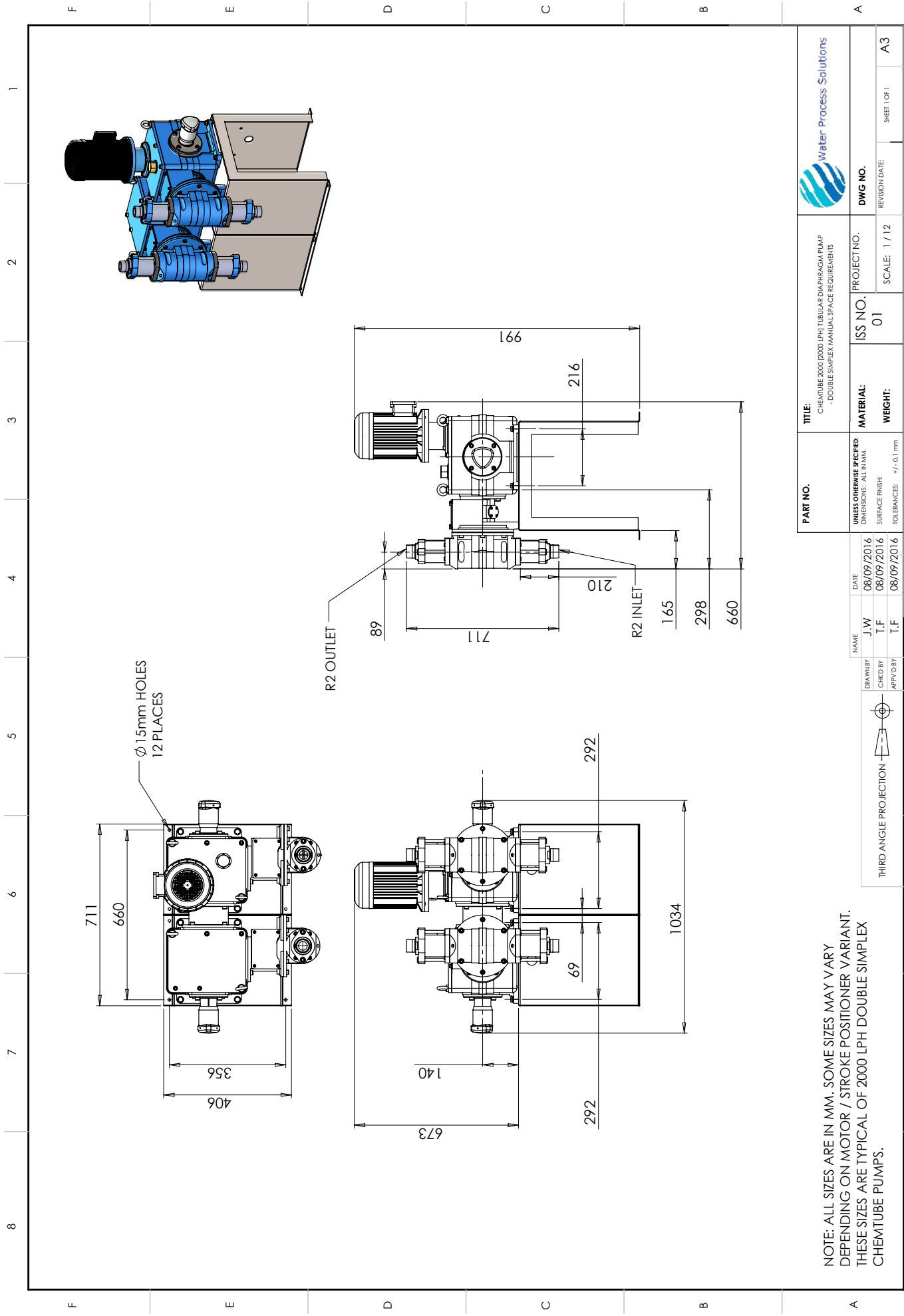

NOTE: ALL SIZES ARE IN MM. SOME SIZES MAY VARY DEPENDING ON MOTOR / STROKE POSITIONER VARIANT. THESE SIZES ARE TYPICAL OF 2000 LPH DOUBLE SIMPLEX CHEMTUBE PUMPS.

PART NO.	TITLE: CHEMTUBURE 2000 (2000 LPH) TUBULAR DIAPHRAGM PUMP - DOUBLE SIMPLEX MANUAL SPACE REQUIREMENTS	PROJECT NO.:	DWG NO.
UNLESS OTHERWISE SPECIFIED: DIMENSIONS: ALL IN MM. SURFACE FINISH: TOLERANCES: ± 0.1 mm	MATERIAL:	ISS NO.: 01	REVISION DATE:
NAME	DATE	SCALE: 1 / 12	SHEET OF 1
DRAWN BY: J.W	08/09/2016		A3
CHECKED BY: T.F	08/09/2016		
APPROVED BY: T.F	08/09/2016		

THIRD ANGLE PROJECTION

Water Process Solutions

Cartridge Valves – Cartridge type suction and discharge valves are utilised for fast service without removing or disconnection piping. The design includes wide flow paths and four-point guides to control ball rise and assure proper seating.

Gear Sets – Five combinations of worm gear and worm shafts are available to provide stroking speeds of 30, 60, 80, 120 and 144 strokes per minute.

Motor – Available with standard induction and variable speed motors [optional] for wider operating ranges and automatic process control.

Air Purge Valve – An air purge automatically removes any entrained air from the hydraulic fluid to maintain pumping accuracy.

Drive Unit – The stroke length is adjusted through a heavy duty, variable eccentric design that provides for non-loss motion operation.

Tubular Diaphragm – The tubular diaphragm provides a straight-through flow path for the process chemical. It is available in Viton® or Hypalon® constructed as standard.

Robust Gearbox – The compact gearbox features liberal use of heavy duty parts including an epoxy-painted cast iron housing, 316SS fasteners, load absorbing tapered roller bearings, robust gears and steel nodular iron drive components.

Secondary Diaphragm – This flat diaphragm separates the hydraulic gearbox oil from the intermediate fluid that surrounds the tubular diaphragm. This provides an extra measure of isolation from the process fluid. This diaphragm also serves to activate the oil refill valve when necessary.

Stroke Adjust Knob – A 10-turn micrometer-type stroke adjuster to obtain precise and highly repeatable feed rate settings. A percent scale and vernier indicate stroke length in 0.25% increments. Feed rate is infinitely adjustable from 0 to 100%. Automatic stroke length control is available with a motor-operated positioner.

Optional Diaphragm Leak Detector – An optional diaphragm leak detector senses the early stages of diaphragm failure. A sensor monitors the intermediate fluid for any change in conductivity, which indicates that either the process chemical or hydraulic oil is mixing with the intermediate fluid due to a diaphragm leak. A remote alarm is initiated to alert the operator.

Oil Refill Valve – The oil refill valve maintains a sufficient volume of hydraulic fluid which is lost in minute quantities through the air-purge valve and the piston/cylinder interface. The secondary diaphragm will eventually flatten against the rear baffle plate. The oil refill valve senses the position of the diaphragm against the baffle plate and combined with a vacuum condition in the pump chamber allows oil replenishment to the pump chamber. There are no valves to adjust and since two conditions must coexist for the refill valve to operate, over-filling of the pump chamber cannot occur even in the case of excessive suction lift or a blocked suction line.

Pressure Relief Valve – An integral, internal pressure relief valve protects the diaphragm and drive unit from overpressure by relieving hydraulic fluid back to the gearbox. The valve is field-set to relieve at 10-15% above the process pressure. This eliminates the need for an external pressure relief valve in the discharge piping system.

Piston – The piston reciprocates within the pump cylinder to provide the pumping action. A close tolerance fit eliminates the need for piston seals.

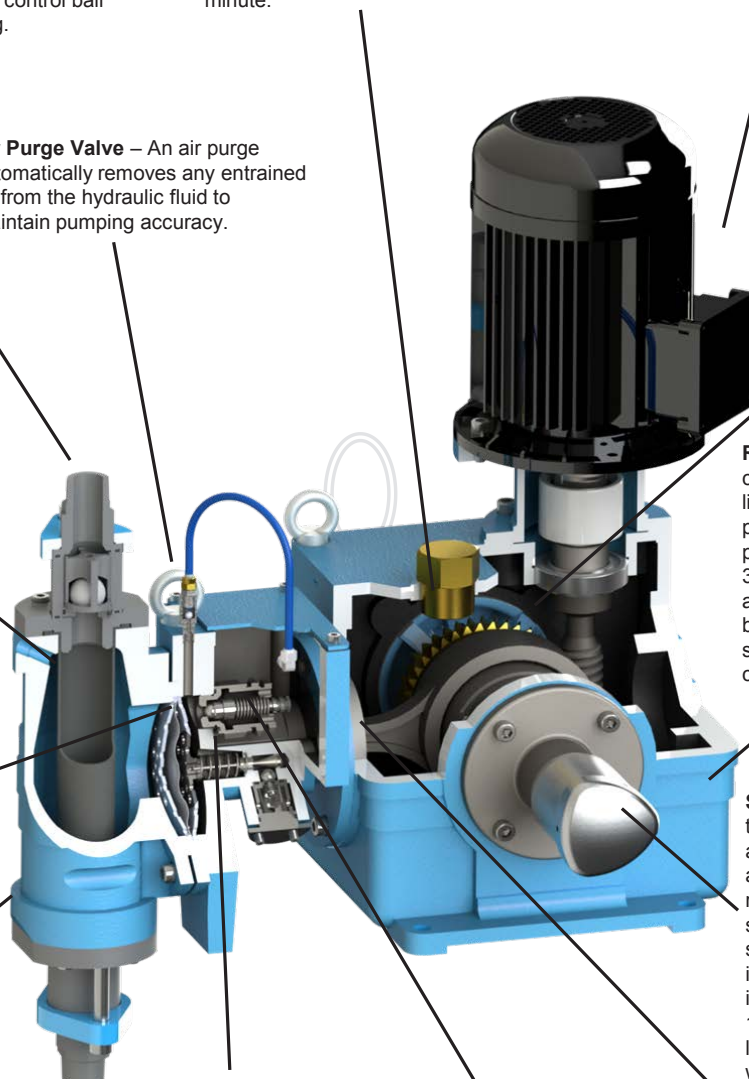

Drive Unit

The motor drives the worm shaft, either directly or through a four-step pulley arrangement, which, in turn, drives the worm gear/sheave guide/eccentric shaft. The different stroking speeds are determined by the pitch and thread of the worm/worm gear combination. The connecting rod rides on the sheave of the eccentric shaft and produces the reciprocating motion of the piston. The gear box is flood-lubricated.

Liquid End

The flat disc diaphragm is flexed hydraulically in a conventional manner by the reciprocating piston. The tubular diaphragm mounted in the head is surrounded by a liquid. This liquid acts as the hydraulic coupling between the two diaphragms.

Hydraulic Coupling

The piston reciprocates within an accurately sized cylinder, displacing an exact volume of oil. The oil serves as an intermediated fluid between the piston and the diaphragm. As the piston displaces the oil through its stroke, the diaphragm flexes causing the process fluid to enter or leave the pump. This ensures that no accuracy or efficiency will be lost due to ballooning of the diaphragm or through the inability of the diaphragm to move through the entire displacement. In order to maintain the balanced hydraulic coupling, a number of different valves are used.

Multiple Head Arrangement

The Chemtube 2000 hydraulically actuated diaphragm pump is available as a simplex and as a double simplex pump, powered by a common drive unit. The liquid ends can have manifolded or separate suction and discharges and may be any combination of two capacities, but will be driven at identical speed (spm).

Electronic Leak Detection (Optional)

The optional leak detection system operates on the principle of conductivity (the ability of a liquid to conduct electricity). The system consists of a conductivity probe and an electronic sensing circuit. In operation the conductivity probe passes a minute electrical current through the high resistance intermediate fluid. If there is a tubular diaphragm rupture, low-resistance process fluid is mixed with intermediate fluid, changing its conductivity, completing the circuit, and activating the alarm. This system will measure the resistivity of a fluid up to 100,000 ohms.

Technical Details

Maximum liquid Temperature:

82°C for 316SS valves; 66°C for Kynar valves;
52°C for PVC valves.

Control:

Stroke length adjustable - Manual
Optional electric Positioner
Electrical speed - Optional SCR.

Ambient Temperature Limits:

-12°C (10°F) to 52°C (126°F)

Accuracy:

+1% of full scale over a 10:1 range.

Operating Range:

10 to 1

Suction Condition:

Flooded suction recommended, suction lift
maximum five feet of water.

Viscosity/Stoke Speed Limits:

10,000 centipoise (Brookfield Viscocometer
with #2 spindle @ 12 rpm) under any condition.
Higher viscosities (up to 20,000 centipoise) with
decreased capacity (10-15%)

Standard Intermediate Fluid:

50/50 propylene glycol and distilled water.

Water Process Solutions comprises a group of highly experienced water treatment professionals. Our personnel have backgrounds with brands and companies such as Wallace & Tiernan, Stranco and Chemfeed, all well known and trusted within the water industry.

Based in Kent, our aim is to provide customers with the equipment and support they need for effective and reliable water treatment.

For further information, visit our website.



www.waterprocesssolutions.com
enquiries@waterprocesssolutions.com

 [WaterProcessSolutions](https://www.facebook.com/WaterProcessSolutions)

 [@waterwps](https://twitter.com/waterwps)

Literature Number WPSSL0500
Revision No. 1 12/08/2019

WATER PROCESS
 **SOLUTIONS**

Water Process Solutions Ltd
Unit 10,
Mill Hall Business Estate,
Aylesford,
Kent, ME20 7JZ